

HGI
HOME STAR

VINYL WINDOWS FOR BETTER LIVING



Welcome Home

HOMESTAR



FEATURING STATE-OF-THE-ART VINYL, GLASS AND SPACER SYSTEMS.

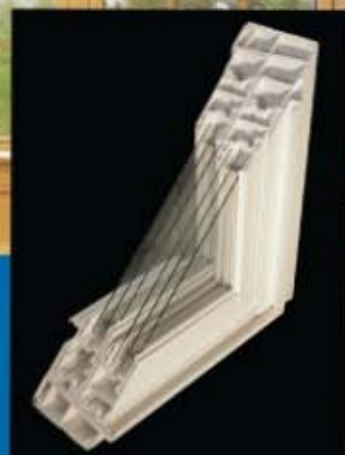

DESIGNED FOR PERFORMANCE

The better living design of the HomeStar™ starts with thick walls of vinyl in a multi-cavity frame. Unique features like interlocking sashes, multi-weatherstripped frames and easy-drain sloped sills provide maximum defense against air and water infiltration.

ALL VINYL IS NOT CREATED EQUAL

Vinyl is clearly the superior material for windows. No maintenance, excellent insulation and strong beyond belief. HomeStar™ vinyl has been chemically formulated to out-perform the competition in color and performance tests.

HOMESTAR ENERGY
PERFORMANCE OPTIONS



ConserVision



ConserVision glass from HomeGuard is the choice for green energy savings benefitting both you and our planet. ConserVision reflects heat back outside keeping your home cool in the summer. In the winter, filtered sunlight helps heat your home (through passive solar gain) while reducing condensation.

ConserVision 100

Features 7/8" overall thermal pane glass with argon gas fill and TripleSilver™ Low-E coating. We add with the XL Stainless Steel warm edge spacer to create a window that is an affordable energy saver.

ConserVision 500

A 7/8" overall triple pane configuration with argon gas fill is a good start. Then we outfit two panes with double silver Low-E coating and add the XL Stainless Steel warm edge spacer. The double silver coating creates exceptional energy efficiency while still allowing passive solar gain for sunny winter days.

ENERGYGUARD 4 7/8" insulated glass with two panels of double strength glass (one clear + one triple coat low E) separated by the warm edge Super Spacer® Premium (cream-colored) and filled with Argon gas.

ENERGYGUARD 10 For the absolute maximum glass insulation, we use three panes of single strength glass (two with Low-E), Super Spacer® Premium and Krypton Gas to reach the pinnacle in insulating glass values.

Every HOME GUARD window ships with this label which shows the unbiased rating of the N.F.R.C (National Fenestration Rating Council). Homestar™ windows consistently receive the highest marks for energy savings and construction excellence.



Energy efficient choices can save about a third on your energy bill with similar savings of greenhouse gas emissions, without sacrificing features, style or comfort.

Save the planet... and save in your pocketbook too.

For more information visit: www.nfrc.org
www.energystar.org

TRIPLE SILVER

3 LAYERS OF SILVER MAKE THE CLEAR DIFFERENCE

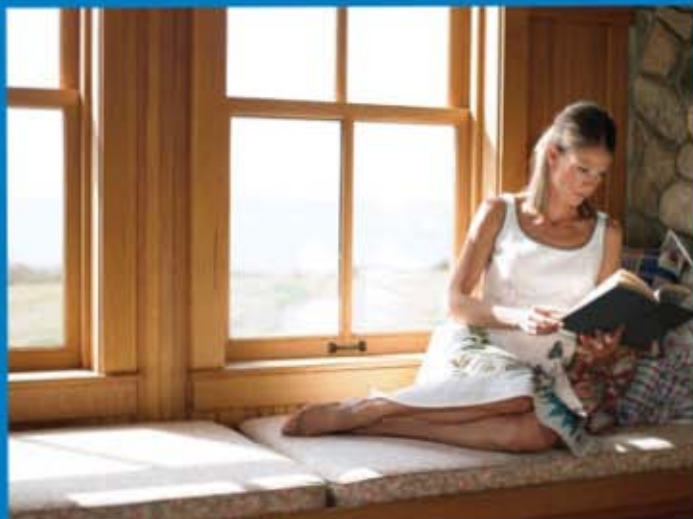

HomeGuard presents the ultimate performance glass. It just might make all other low-E glass obsolete. TripleSilver™ glass delivers the ideal balance of solar control and high visibility. And it provides the highest levels of year-round comfort and energy savings, making it the perfect glass no matter where you live. The secret? An unprecedented triple layer of silver. This is beyond ordinary low-E glass; TripleSilver™ sets the new standard.

GLASS PERFORMANCE

PRODUCT	SOLAR HEAT GAIN COEFFICIENT	WINTER U-FACTOR (AIR/ARGON)	UV	FADING TRANSMISSION
Single-pane, clear	.86	1.04/---	.71	.84
Double-pane, clear	.76	.48/--	.56	.74
Ordinary low-e	.72	.35/.31	.44	.63
ConserVision 100	.27	.29/.24	.05	.43

The full-year benefits of TripleSilver™ can be clearly seen. When the temperature soars in the summer, ordinary window glass just can't beat the heat. TripleSilver™ is formulated to reject solar heat while maintaining attractive visibility. So it keeps the heat out while letting light in.

What is more, TripleSilver™ provides the ultimate in fading protection. It blocks 95% of the sun's damaging ultraviolet rays - a leading cause of fading - so your furniture, carpets, curtains and wall coverings stay beautiful for years. During cold weather, the insulating effect of your windows has a direct impact on how your rooms feel. The better insulated the window glass, the warmer your room will feel.

Additionally, the dramatic comfort improvement in windows with warm glass surfaces means the humidity of the indoor air can be controlled and maintained properly. Proper humidity levels will improve comfort and promote a healthier living environment.



STAINLESS STEEL SPACER SYSTEM

The warm-edge characteristics of the XL Edge Stainless Steel spacer reduces amount of condensation during the most extreme temperature conditions. True warm-edge technology creates a window that is almost as warm at the edges as the center of the glass.



Temperature Outside: -20° +20°

Temperature Inside:

Single Pane	0°	31°
Double Pane Clear	37°	51°
Ordinary Low-e	47°	58°
ConserVision 100	52°	61°





In a universe of windows, there is only one

HOME STAR

What makes our star shine so brightly?

It is the marriage of virgin vinyl with the hand-made craftsmanship of our Amish country factory that creates this outstanding window series. HOMEGUARD® Industries has developed a new generation of windows, built for a lifetime of beauty and a world of energy savings.

The HomeStar™ design features include fully fusion-welded corners on the sashes and frames for an air-tight, water-tight, lifetime bond. The interior of the HomeStar™ is designed with curved millwork to resemble a wood window - without the maintenance of wood. The locking hardware for the HomeStar™ is a specially designed, French curve locking system which is recessed into the rail of the window for clean, unobstructed views.

The HomeStar™ proudly features EnergyGuard® and ConserVision® glass systems - the ultimate in energy saving technology. These systems combine an exclusive high tech spacer with double strength glass prohibiting heat or cold from entering your home. Simply put, this technology is unsurpassed in performance and will dramatically reduce your heating and air conditioning costs.

Exclusive HomeStar™ Features

1. Fully contoured lift rail designed for easy lift
2. Clean corner shadow grooving on fusion welded sash & frame
3. Fully fusion welded sash and frame
4. Beveled Exterior for a new construction look
5. Flush mounted cam action lock for unobstructed view
6. Interlocking sashes remain solid and strong in high winds
7. Safety locking tilt bar allows sash to safely tilt
8. Smooth glide Block & Tackle balance system
9. Equal sight lines for clean, symmetrical appearance
10. Forced entry rated night latch for safe ventilation
11. Low profile tilt latch for sleek design and easy tilting
12. Double strength glass* reduces noise/prevents breakage

(*Dual Pane Units Only)



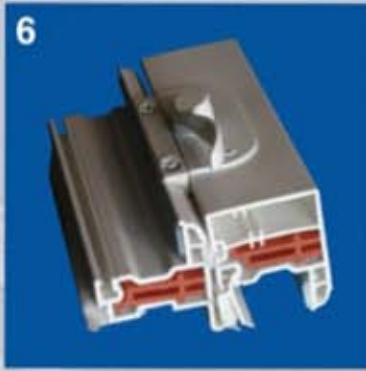

HOME STAR

Double Hung Windows

The HOME GUARD® HomeStar™ double hung style window tilts in for easy cleaning, but won't drop out of the frame like other units due to a unique, patented tilt lock safety system. All HomeStar™ windows can be connected to each other to create dramatic windowscape views - your only limit is your imagination. HomeStar™ windows offer a full array of Conservision™ and EnergyGuard™ glass options, a myriad of decorative glass designs and premium features only found in high end windows.



HOME STAR Slider Windows

The HomeStar™ Horizontal Slider Window offers stylish comfort as well as easy gliding and energy saving HOME GUARD® craftsmanship. Beveled exterior lines, trouble-free brass rollers and lift-out, easy clean sashes provide a bright, modern upgrade to any home. Two or three panel styles are available to produce the panoramic view of a picture window with the functionality of a ventilating window.



HOME STAR

Picture, Casement & Awning Windows

HOME GUARD® Picture, Casement and Awning styles are a perfect addition to both traditional and contemporary homes. Combinations of windows offer unlimited design versatility allowing you to fill your rooms with light and let the beautiful views in. HOME GUARD® advanced window technology and handmade craftsmanship keeps the unwanted elements out.

All HOMEGUARD® Casement & Awning windows carry an AAMA R-80 Light Commercial Rating (the highest residential rating available today). A triple seal design and single handle, multi-point operator makes these casements energy efficient and easy to close.



All HOMEGUARD® casement & awning windows come standard with the Encore® folding/nesting handle and multi-point locking system. The Encore offers strength and easy operation in an attractive and uniquely functional design.



HOME STAR

Bay & Bow Windows



The **HOME GUARD**® Bay and Bow styles provide the ultimate window into your environment while maintaining security and energy efficiency – which has become the **HOME GUARD**® trademark. A stunning variety of styles and combinations will add beauty and lasting value to your home. Consider upgrading your current window openings with a bay or bow to add a dramatic dimension to any room. Optional double hung side operable units are available from our Regency® series only.



- ❶ Polyurethane foam insulation in keystone chambers
- ❷ 3/8" support rod from seatboard to headboard, complete with support cables
- ❸ 1-1/4" oak or birch laminate on seatboard, headboard and jambs
- ❹ All vinyl, perfectly matched closeouts will not dent or scratch.

Optional insulated headboard and seatboard are also available in double-lamination with foam insulation for added energy savings and comfort.



HOME STAR Internal Blinds



Internal blinds add style to your window while providing the opportunity to control lighting and privacy. So easy to use, yet completely maintenance-free – you will never clean or dust your blinds again. Each blind is sealed between two panes of glass making this the perfect choice for homes with children or pets. Internal mini-blinds are available in white and almond for most window types. Casement and awning windows can be ordered with blinds, however the screen must be removed to operate the blind. See your HOME GUARD® representative for further information and available options.



Vinyl Window Colors



Dark Oak



Light Oak



Cherry



Tan



White

Colors are printed representation only - ask representative for an exact color sample.
Wood-look interiors available on white or color-tone exterior only.

TimberLand®

The HomeStar TimberLand® window boasts a beautiful, heavy-gauge laminate that creates the look of real wood without the maintenance or problems of real wood (like rotting and warping). In fact, these windows require NO maintenance (except for the occasional washing). Classic styling, surprising affordability and extra high energy efficiency make the TimberLand® series the choice for homeowners who want the very best.



Light Oak



Dark Oak



Cherry



Windows that almost clean themselves? How NEAT® is that?

Super smooth Neat® coating will provide you with cleaner, low-maintenance glass. It harnesses the sun's UV rays to loosen dirt so water can rinse it away, leaving windows virtually spotless. Your windows will stay cleaner longer and will clean easier. Enjoy the effects that a little sun, rain and Neat glass brings to your windows, including a home that stays cooler in the summer and warmer in the winter. Neat® is complete, as it must be ordered in conjunction with ConserVision glass with energy saving Low-e coating. Clearly, Neat® glass is the choice for your windows.



Neat® is available on ConserVision glass only.

HOME STAR Options

MUNTIN BARS

Muntin bars are available in a myriad of colors, styles and sizes. For woodgrain interiors, ask for two-tone muntins to match. All muntins are between the glass for easy cleaning. Please see your HGI representative for details on the many custom options available.

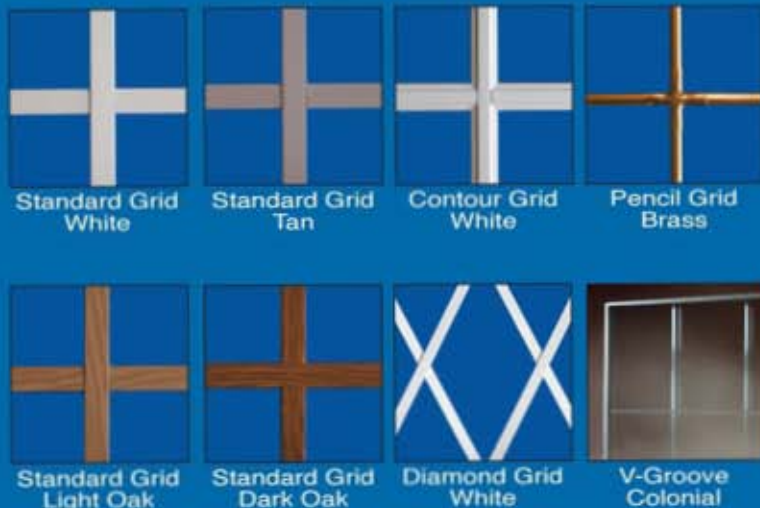

COLOR TONE EXTERIORS

HomeStar™ windows are now available in twelve beautiful exterior color tones for all window styles and patio doors. Through a special process, these windows can be colorized to compliment many exterior color schemes beyond the scope of standard vinyl colors. These colors are also closely matched to or complimentary to Home Guard steel or fiberglass entry door colors. Printed colors may vary - please see your dealer for exact color samples.



COLORS



What Is Low-E Glass? (And Why It Puts Money In Your Pocket.)



All HomeStar™ windows are available with the Low-E (or Low Emissivity) glass option. Low-E has an invisible, metallic coating that admits the full spectrum of sunlight but blocks radiant heat from escaping. In the winter 70-75% of heat normally escaping is reflected back into the home for energy savings. Low-E also increases the window's inside surface temperature, making the area near the window more comfortable. In the summer 25% of unwanted heat is reflected back to the outside, helping to block ultraviolet light which would normally fade fabrics, carpet and furniture.

Clearly Better™

Introducing a revolutionary new screen material with high-tech fiber that allows excellent protection against unwanted pests, but appears very clear (nearly invisible). Now available as an option on all operational HomeStar™ windows. Ask to not see it today!



STANDARD SCREEN

CLEARLY BETTER™



OLD WORLD CRAFTSMANSHIP MEETS MODERN TECHNOLOGY



HOME GUARD Industries' modern, 170,000 sq. ft. manufacturing facility is located on 22 acres right in the heart of the small community of Grabill, Indiana. Grabill is a quaint town of 900 residents, supported by antique and custom cabinet shops. The surrounding area has been farmed by generations of Amish families, well known for their detail and craftsmanship. The Grabill location provides HOME GUARD with the perfect atmosphere to produce custom window and door products with uncompromising efficiency, speed and quality.

Limited Lifetime & Beyond Warranty

HomeStar™ windows are warranted for as long as you own them against chipping, cracking, peeling, pitting, or blistering. Our warranty also covers all moving parts and hardware. The warranty can even be transferred to the next homeowner making the HomeStar™ a sound investment in your home both now and in the future. See Warranty or your dealer for full details.



Authorized Distributor:



HOME GUARD®

© 2012 HOME GUARD® Industries, Inc. • Grabill, Indiana

www.home-guard.net



PROUDLY MADE
IN THE USA